



Rotary Screw Blowers

CBS, DBS, EBS, FBS, GBS, HBS Series

With the world-renowned SIGMA PROFILE 

Flow rate 3 to 160 m³/min, Pressure differential up to 1.1 bar

CBS to HBS series

The rotors in KAESER KOMPRESSOREN's new CBS, DBS, EBS, FBS, GBS and HBS series rotary screw blowers are based on the world-renowned SIGMA PROFILE and have been designed to meet the particular needs of blower applications. So, just like their compressor counterparts, KAESER's rotary screw blowers deliver more compressed air for less energy. The use of premium-quality mechanical and electrical components ensures a powerful, energy-efficient, state-of-the-art blower system that is delivered ready for immediate connection.

Efficient operation

KAESER rotary screw blowers consume significantly less energy than conventional rotary lobe blowers and also achieve significant savings in comparison with turbo blowers. The combination of a blower airend featuring energy-saving SIGMA PROFILE rotors, flow-optimised components, efficient power transmission and high-efficiency drive motors ensures exceptional performance, guaranteed by KAESER in accordance with the stringent tolerances of ISO 1217.

Long-term dependability

Renowned worldwide for the quality of their design, components and manufacture, KAESER products guarantee long-term machine and process availability that you can rely on. High-quality features include durable rotor bearings, a dependable power transmission, precision-dimensioned drive motors, torsion-free sound enclosures with a cleverly designed cooling air flow, SIGMA CONTROL 2 machine controller for efficient and dependable operation – and many more besides.

Cool and quiet

KAESER rotary screw blowers also masterfully manage the balancing act between best possible damping of structure-borne and fluid-borne noise and optimised cooling of the blower airend, drive motor and intake air. In fact, the reduction of fluid-borne noise – pulsations caused by the compressed process air conveyed in the connected piping – has been refined to perfection.

Compressed air at the push of a button

KAESER rotary screw blowers are user-friendly turnkey systems, delivered ready for immediate operation. All that is needed is to connect them to a power supply and the air network. The arduous processes of oil-filling, drive belt installation, motor adjustment, procurement of a suitable frequency converter, programming, cabling in accordance with EMC regulations, drawing circuit diagrams, arranging CE and EMC certification, etc. are thankfully consigned to the past.

Procuring complete, certified machines from systems manufacturers ultimately saves you both time and money, whilst guaranteeing many years of reliable operation.

Ultra and Super Premium Efficiency motors

KAESER rotary screw blowers with flange motors are now equipped with Ultra and Super Premium Efficiency motors (IE5, IE4 and IES2), which stand out for their high energy-saving potential thanks to outstanding levels of efficiency. Saving money has never been so easy!

Guaranteed performance data

To ensure that the projected savings are actually achieved during operation, KAESER quotes effective overall power consumption figures, as well as the usable flow rate, in accordance with the stringent tolerances of ISO 1217, Annexe C or E (as applicable).



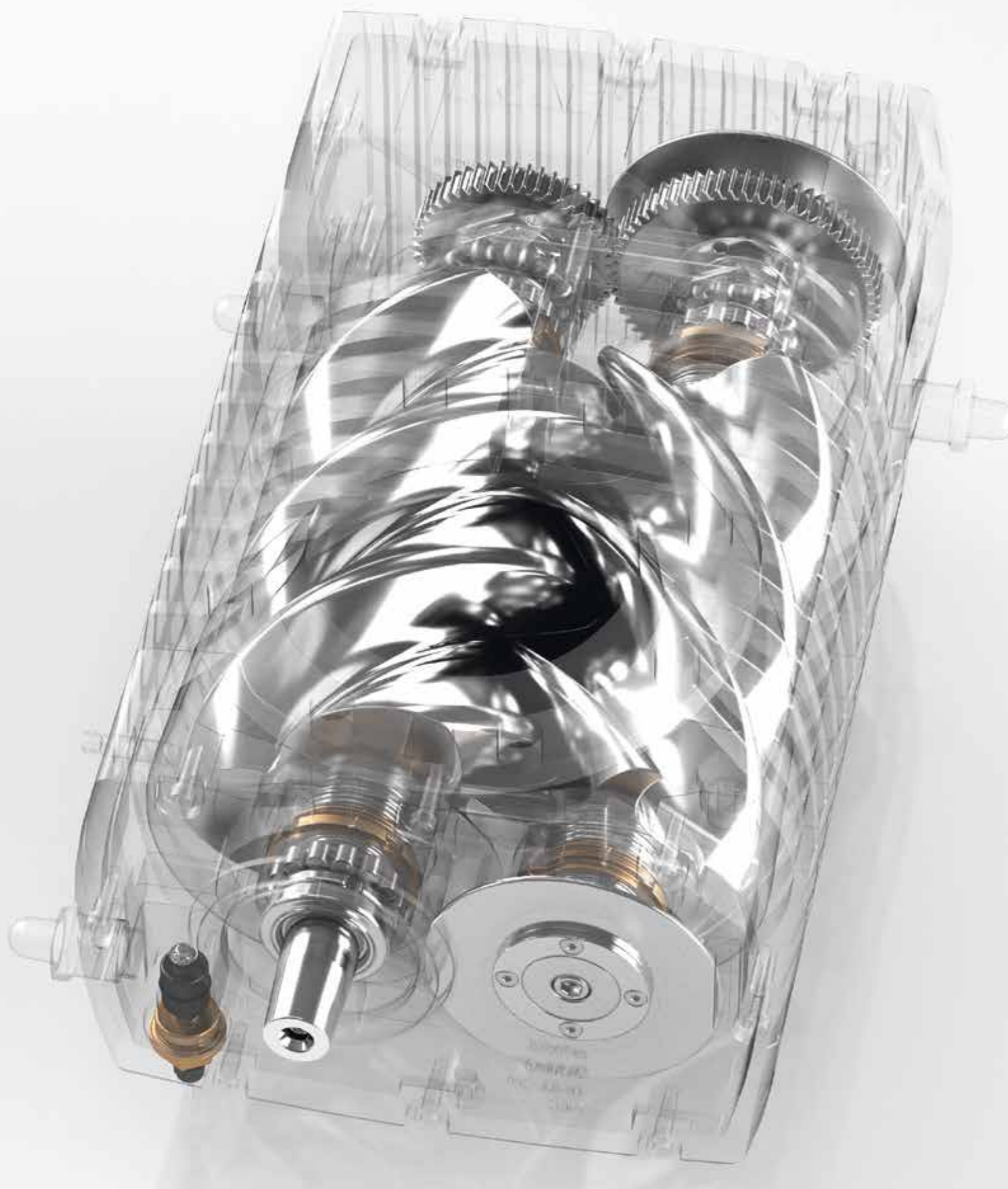

CBS, DBS, EBS, FBS, GBS, HBS series

Pure efficiency with the SIGMA PROFILE

Developed in the early 1970s, KAESER's SIGMA PROFILE rotor technology revolutionised rotary screw compressor energy efficiency. Continually refined ever since at KAESER's Research and Development Centres in Coburg and Gera, this high-efficiency compressor technology is now available for use in blower systems as well.

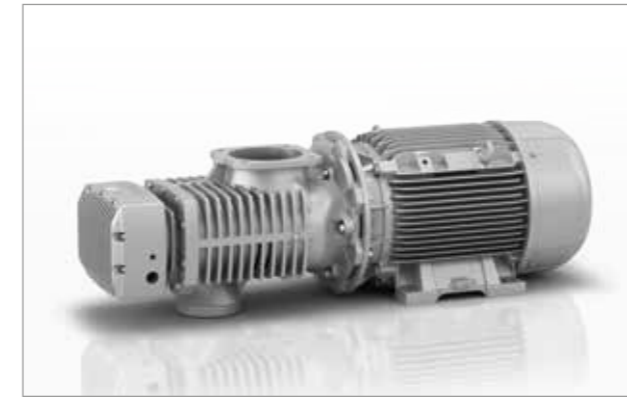

Blower airoend with SIGMA PROFILE

KAESER's high-efficiency blower airoends combine a wide control range with near constant specific package input power. Equipped with energy-efficient SIGMA PROFILE rotors, they ensure maximum air delivery whilst keeping power consumption to an absolute minimum.



Dependable seals

Field-proven in KAESER rotary screw compressors, the sliding ring seal for the rotary transmission drive shaft lead-through on the blower airoend housing is completely maintenance-free and guarantees dependable sealing performance, even in hot or dusty environments.



Durable bearings

Four robust cylinder roller bearings absorb 100% of the radial forces, thereby ensuring a long service life for the airoend. The rolling elements are encased in high-tech cages for optimum lubrication at all speeds.



Continuous system monitoring

Sensors for oil level and temperature monitoring are integrated into the blower airoend. The inside of the oil chamber is designed to ensure these continue to function whilst the machine is operating – even with fluctuating oil levels. Clever cooling design means KAESER rotary screw blowers require minimal oil.

CBS to HBS series

Direct drive – Ultimate efficiency



In CBS to GBS series rotary screw blowers, power is transferred from the motor to the blower airend via a lossless and maintenance-free gear transmission. This has proven to be the best solution for the prevailing speeds in this performance and size class when it comes to efficiency, reliability and durability.

With HBS series blowers, power is transferred directly without loss via a coupling. These concepts were the result of extensive research at KAESER's Research and Development Centres.

The transmission ratio can be varied using different sets of timing gears so that, for example, the motor can be used at all times within the optimum frequency range of the SFC's variable speed control, or in the case of fixed-speed operation, flow rate can be matched to actual demand. Moreover, the combination of low lateral forces on the motor shaft and low-speed operation helps to ensure a long service life for the motor bearings.

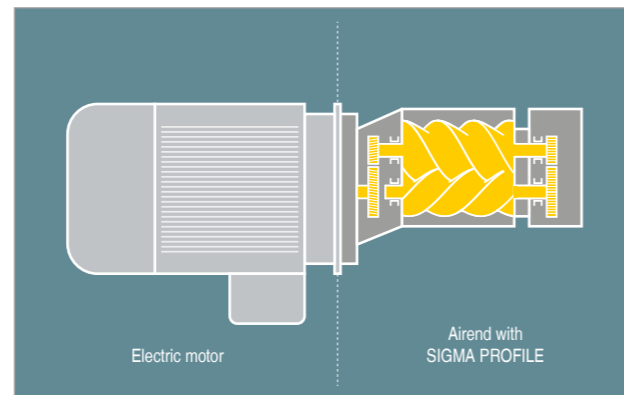

SIGMA B blower airend

Providing exceptional efficiency and optimum reliability, the airend does not require any auxiliary equipment, such as an oil or vacuum pump, or an oil cooler.

CBS to GBS series from 7.5 to 110 kW

Pure efficiency with synchronous reluctance motors



High-efficiency synchronous reluctance motor

As a slip-free motor, this design combines all the benefits of high-efficiency permanent-magnet motors with those of robust, maintenance-friendly asynchronous motors. No aluminium, copper, rare-earth elements or magnets are used for the rotors. Instead, they are constructed from electrical steel with a specialised profile and arranged in series. This makes the drive highly durable and easy to service.



With high-performance frequency converter

The Siemens frequency converter uses a control algorithm that is specifically adapted to the motor. With the perfectly matched combination of frequency converter and synchronous reluctance motor, KAESER achieves the highest possible system efficiency class of IES2 as per IEC 61800-9-2.

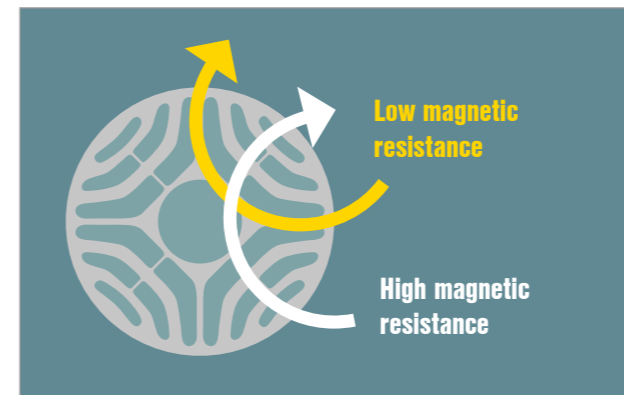

How the reluctance motor works

In a synchronous reluctance motor, the torque is generated by magnetic reluctance forces. The rotor features salient poles and is made of a soft magnetic material, such as electrical steel, which is highly permeable to magnetic fields. This enables it to achieve the highest possible efficiency class of IE5.



High efficiency in partial load operation

Synchronous reluctance motors achieve significantly higher efficiency in the partial load range than, for example, asynchronous motors. This helps achieve savings of up to 10% in comparison with conventional variable-speed systems.

Efficient and dependable

The blower airend plays a key role in ensuring outstanding energy efficiency. It achieves this thanks to a combination of precisely matched components and the advanced control provided by the SIGMA CONTROL 2 blower controller.



The blower controller

The SIGMA CONTROL 2 ensures efficient blower control and monitoring at all times. A readout display, RFID reader and numerous interfaces enable fast and reliable communication, whilst the SD card slot makes data storage and software updates a breeze. In the event of a failure of the master control system, the blower will switch automatically to individual operation and can be controlled manually – ensuring a continued supply of quality compressed air for the applicable process.



Comprehensive sensors

A wide range of sensors and switches for monitoring pressure, temperature, speed, oil level and filters ensures dependable operation of the blower, whilst allowing remote monitoring and visualisation of operating status.

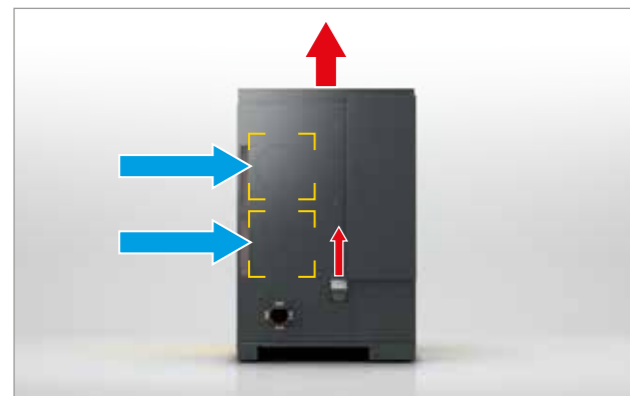

Cool intake air

Process air and cooling air for the motor are drawn in separately from outside the sound enclosure. This boosts efficiency and leads to a higher usable mass flow rate for the same power consumption. The blowers can operate in ambient temperatures up to +45 °C.

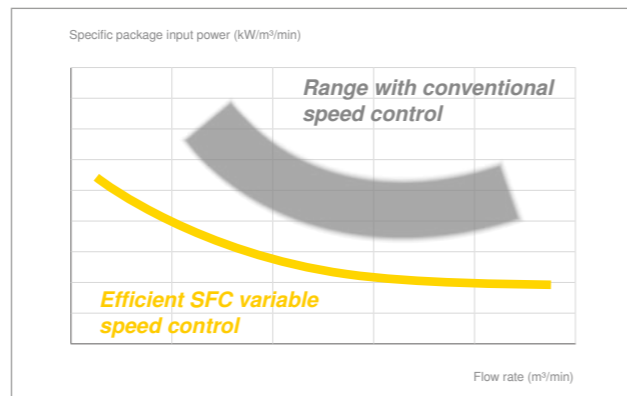

Optimised specific package input power

The moderate maximum speed, an extra-dense screw profile and near constant specific package input power across a wide, variable-speed control range all combine to achieve significant energy savings across the entire operating curve.





CBS to HBS series

Plug-and-play

KAESER rotary screw blowers are delivered as turnkey complete machines, which saves operators a time-consuming and cost-intensive installation procedure.

Moreover, they are supplied ex works ready for integration into Industrie 4.0 applications.



START CONTROL (STC)

The version with integrated star-delta starter for constant-speed operation is equipped with a premium contactor, overcurrent relay and phase monitoring. A SIGMA CONTROL 2 controller and dependable emergency stop system complete the package (not available with HBS).



SIGMA FREQUENCY CONTROL (SFC)

Using variable speed control, the SFC frequency converter adjusts flow rate to match the actual air demand of the process application. Everything is delivered ready for immediate operation, since all programming and parametrisation is carried out at the factory.



Plug-and-play

These turnkey blowers are delivered complete with all sensors, STC/SFC, SIGMA CONTROL 2 and an emergency stop switch, are ready-filled with oil and are fully certified. This significantly reduces the work and costs required for planning, installation, certification, documentation and commissioning.



EMC-certified complete system

It goes without saying that the SFC control cabinet and SIGMA CONTROL 2 are tested and certified for electromagnetic compatibility, both as individual components and as complete blower systems, in accordance with EMC Directive EN 55011 for Class A1 industrial power supplies.

CBS to HBS series

A new standard for the low pressure segment

KAESER's innovative CBS, DBS, EBS and FBS series rotary screw blowers not only impress with their energy-saving drive concept, but also with their well thought-out and compact design, which allows all maintenance work to be performed from the front. Side-by-side installation is possible even with all electrical equipment. Because they provide even more power and are therefore larger, GBS and HBS systems require more installation space. A certain minimum clearance is consequently required to ensure sufficient service accessibility.



Exceptionally compact

Comprising a blower airend with drive motor, loss-free power transmission, silencers, sensors, controller and electrical equipment such as frequency converter or star-delta starter, this compact powerhouse features a footprint of just 1.65 m² (DBS), whilst the fully automated 75 kW EBS model boasts a footprint of only 2.5 m².



Side-by-side installation

The package layout of CBS to FBS series rotary screw blowers has been designed to allow all maintenance work to be performed from the front of the unit. These compact blowers can therefore be installed side by side without the need for any additional work.



Flow-optimised

All relevant components, including on the intake side, are flow-optimised to minimise pressure losses. Silencers, air filters and non-return flaps also help us to stay true to our motto of providing "More compressed air for less energy".



Quieter than ever before

Highly effective sound damping not only minimises machine noise via the sound enclosure; special absorption silencers also help significantly to reduce fluid-borne noise transmitted through the piping – a characteristic commonly associated with speed-controlled blowers.

More compressed air for less energy



Image: EBS 410 CM SFC



Image: Four HBS 1600 M SFC units with SAM 4.0 station controller at a wastewater treatment plant

Equipment

Ultra and Super Premium Efficiency motors

Siemens/Innomotics brand; Ultra and Super Premium Efficiency motors with IE5 and IE4 efficiency classes / IES2 system efficiency class; perfectly matched SFC frequency converter on speed-controlled systems; Pt100 fitted as standard; central, easily accessible lubrication points for re-lubricatable motor bearings ensure quick, safe maintenance; motor bearings generously dimensioned – first replacement after 60,000 operating hours.

SIGMA CONTROL 2

“Traffic light” LED indicators show operating status at a glance, plain text display, 30 selectable languages, soft-touch keys with icons, fully automatic monitoring and control. Interfaces: Ethernet; additional optional communication modules for Profibus DP, Modbus RTU and / TCP, Profinet IO, EtherNet/IP and DeviceNet. RFID card reader, web server, KAESER CONNECT user interface, visualisation of signals at analogue and digital inputs, warning and fault messages, graphic display of pressure, temperature and speed trends. SD card reader for storage of process data, operating hours, working hours, warning and fault messages; updates via SD card.

Pulsation dampers

Efficient intake- and discharge-side absorption silencers with wide frequency range to mitigate unwanted process air pulsations; excellent damping of fluid-borne noise transmitted through piping. Discharge-free and long-lasting.

KAESER CONNECT

Create a LAN connection between PC and SIGMA CONTROL 2 via the Ethernet interface; launch Internet browser; enter SIGMA CONTROL 2 IP address and input password: access blower controller via the integrated web server. User interface displays machine status in real time and signals at the analogue and digital inputs, lists warning and fault messages and graphically displays pressure, temperature and speed trends. (See image below)

Master/Slave operation

Two identical/different blowers connected via Ethernet; automatic changeover for standby/ready with operating hours balancing; control of two blowers possible by use of adjustable switching range.

Further optimisation



SIGMA AIR MANAGER 4.0

The SIGMA CONTROL 2 internal compressor / blower controller and the SIGMA AIR MANAGER 4.0 master controller provide more than just optimised blower air system efficiency. Thanks to their high level of data integration and multiple interface options, they can be easily integrated into advanced production, building management and energy management systems, as well as Industrie 4.0 application environments.



Optimum conditions

Carefully matched peripheral components, such as weather protection screens, supplementary fans and sound dampers in the inlet and outlet ducting, help maintain a pleasant working environment.



Heat recovery

Heat exchangers can cool the process air significantly, even at high ambient temperatures. The heat gained can therefore be utilised for the purposes of space heating and/or water heating, thereby considerably reducing primary energy costs.



Cooler

With minimal differential pressure, the economical ACA-type air/air aftercooler uses a temperature switch to limit the blower air temperature reliably to 10 Kelvin above ambient.

Design

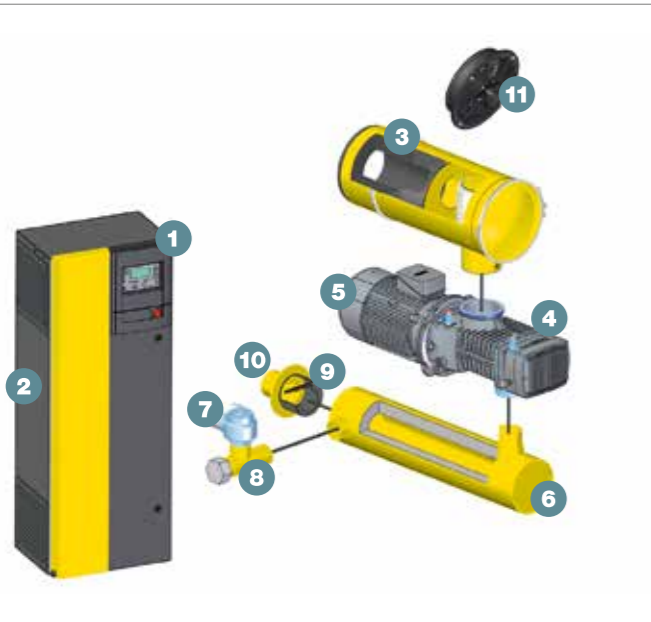

- 01) SIGMA CONTROL 2 controller
- 02) STC or SFC control cabinet
- 03) Intake silencer with filter
- 04) Blower airend with SIGMA PROFILE
- 05) IE4/IES2 – Super Premium Efficiency motor
- 06) Discharge silencer
- 07) Pressure valve
- 08) Unloaded-start valve (optional)
- 09) Non-return flap (optional)
- 10) Compensator
- 11) Sound enclosure fan

Views



Technical data

Model	Max. flow rate *)	Gauge pressure	Vacuum	Max. rated motor power	Pipe connection	Dimensions with control cabinet W x D x H	Max. weight
	m ³ /min	Max. pressure differential mbar	Max. pressure differential mbar				
CBS 121 L SFC	12.6	700	–	18.5	80	1110 x 1370 x 1670	750
CBS 121 M SFC	12.5	1100	550	22			
CBS 121 L STC	10.3	700	–	18.5			
CBS 121 M STC	10.2	1100	–	22			
DBS 221 L SFC	23	700	–	30	100	1110 x 1480 x 1670	850
DBS 221 M SFC	22	1100	550	37			
DBS 221 L STC	19	700	–	22			
DBS 221 M STC	18	1100	–	37			
EBS 410 CL SFC	41	700	–	37	150	1280 x 1760 x 1820	1400
EBS 410 CM SFC	30	1000	550				
EBS 410 L SFC	41	700	–	55		1460 x 1760 x 1970	1520
EBS 410 M SFC	40	1100		75			
EBS 410 CL STC	38	700		37		1280 x 1760 x 1820	1400
EBS 410 CM STC	30	1000		55			
EBS 410 L STC	40	700	75	1460 x 1760 x 1970		1520	
EBS 410 M STC	40	1100	75				
FBS 720 L SFC	72.5	700	–	90	200	1460 x 2330 x 1970	2200
FBS 720 M SFC	71.5	1100	550	110			
FBS 720 L STC	71.5	700	–	75			
FBS 720 M STC	71.5	1100	–	75			
GBS 1050 L SFC	105.1	700	–	132	250	1870 x 2700 x 2260	4100
GBS 1050 M SFC	104.3	1100	550	160			
GBS 1050 L STC	104.1	700	–	132			
GBS 1050 M STC	103.3	1100	–	160			
HBS 1600 L SFC	160	700	550	200	300	2070 x 3720 x 2230	6000
HBS 1600 M SFC	160	1100	–	250			

*) Performance specifications as per ISO 1217 Annexe C for STC version, Annexe E for SFC version

More compressed air for less energy

The world is our home

As one of the world's largest manufacturers of compressors, blowers and compressed air systems, KAESER KOMPRESSOREN is represented throughout the world by a comprehensive network of wholly owned subsidiaries and authorised distribution partners in over 140 countries.

By offering innovative, efficient and reliable products and services, KAESER KOMPRESSOREN's experienced consultants and engineers work in close partnership with customers to enhance their competitive edge and to develop progressive system concepts that continuously push the boundaries of performance and technology. Moreover, decades of knowledge and expertise from this industry-leading systems provider are made available to each and every customer via the KAESER group's advanced global IT network.

These advantages, coupled with KAESER's worldwide service organisation, ensure that every product operates at the peak of its performance at all times, providing optimal efficiency and maximum availability.



KAESER COMPRESSORS (INDIA) PVT. LTD.

Plot No. 1 & 2 • Survey No. 297, 298, 299 • Indo German Technology Park • Village Urawade Taluka
Mulshi • District. Pune • 412115

Tel.: 0091 20 - 66769240 & 66769205 • Fax: 0091 20 - 66769238

E-mail: info.india@kaeser.com • www.kaeser.com